

# Autodesk® Education Suite for Entertainment Creation

Inspire students to pursue exciting careers in digital arts with powerful computer graphics tools used by industry professionals around the world.

Prepare the next generation of digital artists with a comprehensive software suite that provides industry-standard tools and access to a variety of online curriculum and self-paced resources.



Image courtesy of Sony Computer Entertainment & Insomniac Games.

Future game developers and aspiring film, television, and visual effects artists depend on educators' ability to provide them with top-notch industry expertise, solid skill sets, and fluency with industry-leading tools. The Autodesk Education Suite for Entertainment Creation includes software titles that are among the top choices by industry professionals who use these tools to create award-winning and engaging projects. In addition to an innovative software toolset, Autodesk offers access to a variety of online, self-paced curriculum and learning resources.

## Key Benefits

- Offers a wide range of artist-driven tools designed to handle tough production challenges.
- The addition of Autodesk® MotionBuilder® software provides students with a powerful yet user-friendly interface to help create, control, and change animation dynamics, character behavior, story structure, cameras, lighting, and other crucial aspects of film and games production.
- Designed by professional artists in the film, games, and design industries, Autodesk® Mudbox™ software gives 3D modelers and texture artists the freedom to create without worrying about technical details.
- Provides schools and students with access to a powerful range of creative toolsets at a significant cost savings, compared with purchasing a license of each product individually.
- Offers students and educators free\* learning and curriculum materials, software for personal use, and discussion forums—all accessible through the Autodesk Education Community at [www.autodesk.com/edcommunity](http://www.autodesk.com/edcommunity) with additional interaction with industry leaders at the AREA ([www.autodesk.com/area](http://www.autodesk.com/area)).

The Autodesk Education Suite for Entertainment Creation includes the following 2D and 3D design software products:

- Autodesk® Maya®
- Autodesk® MotionBuilder®
- Autodesk® Mudbox™
- Autodesk® SketchBook® Pro
- Autodesk® Softimage®
- Autodesk® 3ds Max®

#### Autodesk Learning Resources for Educators

Integrate Autodesk® technology in your classroom with free\* resources and lesson plans from the Autodesk Education Community and AREA Community sites. By joining these communities, educators will gain access to a wide range of materials, including curricula, interactive exercises, and modular projects for entertainment and games faculties.

The following title is an example of curriculum that supports the Autodesk Education Suite for Entertainment Creation:

- **Autodesk® Industry Careers Framework for Games and Animation:** Approaches learning 3D through the core subjects taught in traditional creative studies, including modules on animation and interactive 3D space.

#### Learn More or Purchase

Academic institutions can purchase in a variety of configurations with flexible licensing terms designed to help meet the needs of the smallest classroom to the largest university system. Autodesk offers institutions and schools affordable pricing on Autodesk® software, curricula, and training, including significant discounts for volume purchases. Autodesk Education Suites are generally available in both one-year term and perpetual license forms† Autodesk Education Suites can be installed using either stand-alone or network licensing.

To purchase the Autodesk Education Suite for Entertainment Creation, contact an Autodesk Education Reseller. Visit [www.autodesk.com/reseller](http://www.autodesk.com/reseller) to locate the reseller nearest you. Go to [www.autodesk.com/entertainmentsuite-edu](http://www.autodesk.com/entertainmentsuite-edu) to learn more about the software.

#### Autodesk Subscription

Education suites are offered with the option of purchasing Autodesk Subscription to gain access to web-based technical support, updates, product extensions, other software entitlements, and additional training and learning content. Visit [www.autodesk.com/subscription](http://www.autodesk.com/subscription) to learn more.

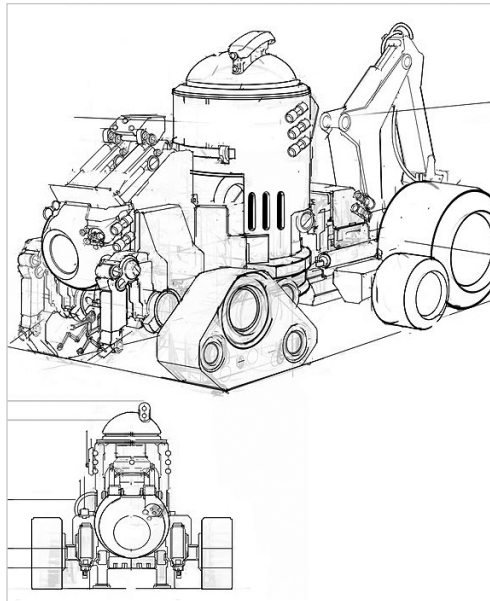

\* Free products are subject to the terms and conditions of the end-user license agreement that accompanies download of the software. The software is for personal use for education purposes and is not intended for classroom or lab use.

† Some suites may not be offered in both term and perpetual licenses in certain regions.

Autodesk, Maya, MotionBuilder, Mudbox, SketchBook, Softimage, and 3ds Max are registered trademarks or trademarks of Autodesk, Inc., and/or its subsidiaries and/or affiliates in the USA and/or other countries. All other brand names, product names, or trademarks belong to their respective holders. Autodesk reserves the right to alter product and services offerings, and specifications and pricing at any time without notice, and is not responsible for typographical or graphical errors that may appear in this document.